

# ESP32-C3 Series

## Datasheet

Ultra-Low-Power SoC with RISC-V Single-Core CPU

Supporting IEEE 802.11b/g/n (2.4 GHz Wi-Fi) and Bluetooth<sup>®</sup> 5 (LE)

### Including:

ESP32-C3

ESP32-C3FN4

ESP32-C3FH4



Version 1.1  
Espressif Systems  
Copyright © 2021

# Product Overview

ESP32-C3 series of SoCs is an ultra-low-power and highly-integrated MCU-based solution that supports 2.4 GHz Wi-Fi and Bluetooth® Low Energy (Bluetooth LE). The block diagram of ESP32-C3 is shown below.

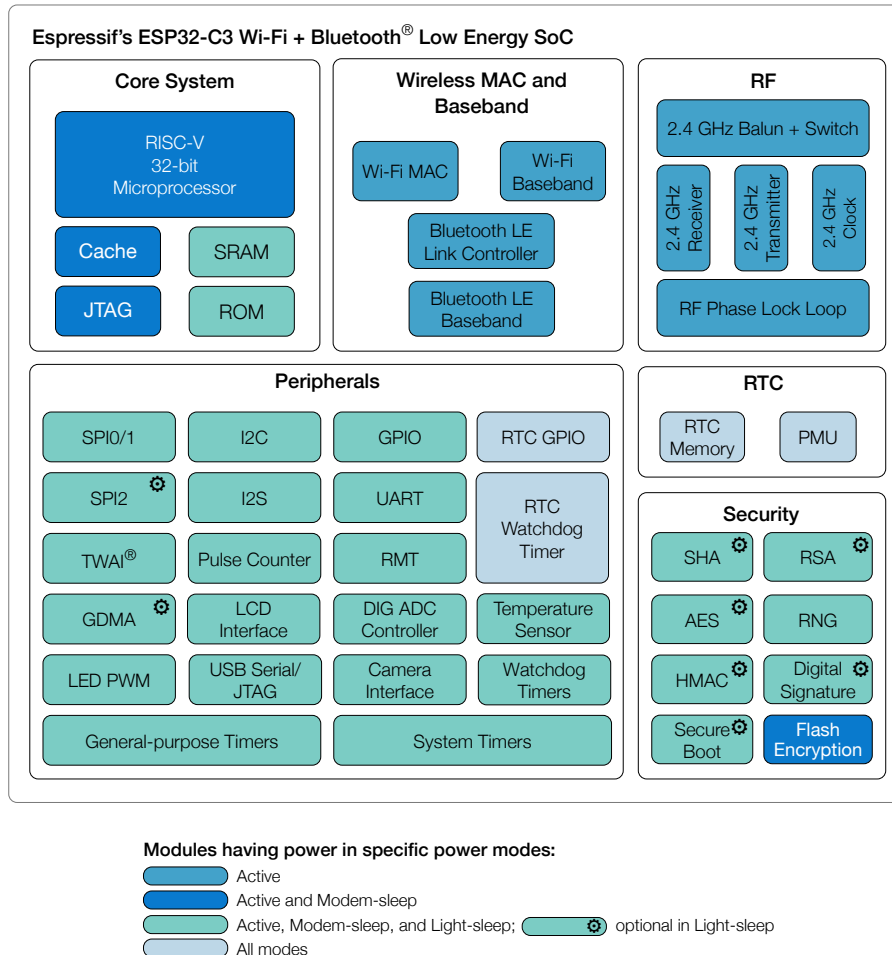

Figure 1: Block Diagram of ESP32-C3

## Solution Highlights

- **A complete Wi-Fi subsystem** that complies with IEEE 802.11b/g/n protocol and supports Station mode, SoftAP mode, SoftAP + Station mode, and promiscuous mode
- **A Bluetooth LE subsystem** that supports features of Bluetooth 5 and Bluetooth mesh
- **32-bit RISC-V single-core processor** with a four-stage pipeline that operates at up to 160 MHz
- **State-of-the-art power and RF performance**
- **Storage capacities** ensured by 400 KB of SRAM (16 KB for cache) and 384 KB of ROM on the chip, and SPI, Dual SPI, Quad SPI, and QPI interfaces that allow connection to external flash
- **Reliable security features** ensured by
  - Cryptographic hardware accelerators that support AES-128/256, Hash, RSA, HMAC, digital signature and secure boot
  - Random number generator
  - Permission control on accessing internal

- memory, external memory, and peripherals
- External memory encryption and decryption

- **Rich set of peripheral interfaces and GPIOs**, ideal for various scenarios and complex applications

## Features

### Wi-Fi

- IEEE 802.11 b/g/n-compliant
  - Supports 20 MHz, 40 MHz bandwidth in 2.4 GHz band
  - 1T1R mode with data rate up to 150 Mbps
  - Wi-Fi Multimedia (WMM)
  - TX/RX A-MPDU, TX/RX A-MSDU
  - Immediate Block ACK
  - Fragmentation and defragmentation
  - Transmit opportunity (TXOP)
  - Automatic Beacon monitoring (hardware TSF)
  - 4 × virtual Wi-Fi interfaces
  - Simultaneous support for Infrastructure BSS in Station mode, SoftAP mode, Station + SoftAP mode, and promiscuous mode
- Note that when ESP32-C3 scans in Station mode, the SoftAP channel will change along with the Station channel*
- Antenna diversity
  - 802.11mc FTM
  - Supports external power amplifier

### Bluetooth

- Bluetooth LE: Bluetooth 5, Bluetooth mesh
- High power mode (18 dBm)
- Speed: 125 Kbps, 500 Kbps, 1 Mbps, 2 Mbps
- Advertising extensions
- Multiple advertisement sets
- Channel selection algorithm #2
- Internal co-existence mechanism between Wi-Fi and Bluetooth to share the same antenna

### CPU and Memory

- 32-bit RISC-V single-core processor, up to 160 MHz
- CoreMark® score:
  - 1 core at 160 MHz: 407.22 CoreMark; 2.55 CoreMark/MHz
- 384 KB ROM
- 400 KB SRAM (16 KB for cache)
- 8 KB SRAM in RTC
- Embedded flash (see details in Chapter 1 [ESP32-C3 Series Comparison](#))
- SPI, Dual SPI, Quad SPI, and QPI interfaces that allow connection to multiple external flash
- Access to flash accelerated by cache
- Supports flash in-Circuit Programming (ICP)

### Advanced Peripheral Interfaces

- 22 × programmable GPIOs
- Digital interfaces:
  - 3 × SPI
  - 2 × UART
  - 1 × I2C
  - 1 × I2S
  - Remote control peripheral, with 2 transmit channels and 2 receive channels
  - LED PWM controller, with up to 6 channels
  - Full-speed USB Serial/JTAG controller
  - General DMA controller (GDMA), with 3 transmit channels and 3 receive channels
  - 1 × TWAI® controller compatible with ISO 11898-1 (CAN Specification 2.0)
- Analog interfaces:

- 2 × 12-bit SAR ADCs, up to 6 channels
- 1 × temperature sensor
- Timers:
  - 2 × 54-bit general-purpose timers
  - 3 × watchdog timers
  - 1 × 52-bit system timer

### Low Power Management

- Power Management Unit with four power modes

### Security

- Secure boot

- Flash encryption
- 4096-bit OTP, up to 1792 bits for use
- Cryptographic hardware acceleration:
  - AES-128/256 (FIPS PUB 197)
- Permission Control
- SHA Accelerator (FIPS PUB 180-4)
- RSA Accelerator
- Random Number Generator (RNG)
- HMAC
- Digital signature

## Applications (A Non-exhaustive List)

With ultra-low power consumption, ESP32-C3 is an ideal choice for IoT devices in the following areas:

- [Smart Home](#)
  - Light control
  - Smart button
  - Smart plug
  - Indoor positioning
- [Industrial Automation](#)
  - Industrial robot
  - Mesh network
  - Human machine interface (HMI)
  - Industrial field bus
- [Health Care](#)
  - Health monitor
  - Baby monitor
- [Consumer Electronics](#)
  - Smart watch and bracelet
  - Over-the-top (OTT) devices
- Wi-Fi and Bluetooth speaker
- Logger toys and proximity sensing toys
- Smart Agriculture
  - Smart greenhouse
  - Smart irrigation
  - Agriculture robot
- Retail and Catering
  - POS machines
  - Service robot
- Audio Device
  - Internet music players
  - Live streaming devices
  - Internet radio players
- Generic Low-power IoT Sensor Hubs
- Generic Low-power IoT Data Loggers

# Contents

<b>Product Overview</b>	2
Solution Highlights	2
Features	3
Applications	4
<b>1 ESP32-C3 Series Comparison</b>	9
1.1 ESP32-C3 Series Nomenclature	9
1.2 Comparison	9
<b>2 Pin Definition</b>	10
2.1 Pin Layout	10
2.2 Pin Description	10
2.3 Power Scheme	12
2.4 Strapping Pins	13
<b>3 Functional Description</b>	16
3.1 CPU and Memory	16
3.1.1 CPU	16
3.1.2 Internal Memory	16
3.1.3 External Flash	16
3.1.4 Address Mapping Structure	17
3.1.5 Cache	17
3.2 System Clocks	18
3.2.1 CPU Clock	18
3.2.2 RTC Clock	18
3.3 Analog Peripherals	18
3.3.1 Analog-to-Digital Converter (ADC)	18
3.3.2 Temperature Sensor	18
3.4 Digital Peripherals	18
3.4.1 General Purpose Input / Output Interface (GPIO)	18
3.4.2 Serial Peripheral Interface (SPI)	20
3.4.3 Universal Asynchronous Receiver Transmitter (UART)	21
3.4.4 I2C Interface	21
3.4.5 I2S Interface	22
3.4.6 Remote Control Peripheral	22
3.4.7 LED PWM Controller	22
3.4.8 General DMA Controller	22
3.4.9 USB Serial/JTAG Controller	22
3.4.10 TWAI <sup>®</sup> Controller	22
3.5 Radio and Wi-Fi	23
3.5.1 2.4 GHz Receiver	23
3.5.2 2.4 GHz Transmitter	23
3.5.3 Clock Generator	24

3.5.4	Wi-Fi Radio and Baseband	24
3.5.5	Wi-Fi MAC	24
3.5.6	Networking Features	25
3.6	Bluetooth LE	25
3.6.1	Bluetooth LE Radio and PHY	25
3.6.2	Bluetooth LE Link Layer Controller	25
3.7	Low Power Management	26
3.8	Timers	26
3.8.1	General Purpose Timers	26
3.8.2	System Timer	26
3.8.3	Watchdog Timers	26
3.9	Cryptographic Hardware Accelerators	27
3.10	Physical Security Features	27
3.11	Peripheral Pin Configurations	27
<b>4</b>	<b>Electrical Characteristics</b>	<b>30</b>
4.1	Absolute Maximum Ratings	30
4.2	Recommended Operating Conditions	30
4.3	VDD_SPI Output Characteristics	30
4.4	DC Characteristics (3.3 V, 25 °C)	31
4.5	ADC Characteristics	31
4.6	Current Consumption	32
4.7	Reliability	32
4.8	Wi-Fi Radio	33
4.8.1	Wi-Fi RF Transmitter (TX) Specifications	33
4.8.2	Wi-Fi RF Receiver (RX) Specifications	34
4.9	Bluetooth LE Radio	35
4.9.1	Bluetooth LE RF Transmitter (TX) Specifications	36
4.9.2	Bluetooth LE RF Receiver (RX) Specifications	37
<b>5</b>	<b>Package Information</b>	<b>40</b>
<b>6</b>	<b>Related Documentation and Resources</b>	<b>41</b>
	<b>Revision History</b>	<b>42</b>

## List of Tables

1	ESP32-C3 Series Comparison	9
2	Pin Description	10
3	Description of ESP32-C3 Power-up and Reset Timing Parameters	13
4	Strapping Pins	14
5	Parameter Descriptions of Setup and Hold Times for the Strapping Pins	15
6	IO MUX Pin Functions	19
7	Power-Up Glitches on Pins	20
8	Mapping of SPI Signals and Chip Pads	21
9	Connection Between ESP32-C3 and External Flash	21
10	Peripheral Pin Configurations	27
11	Absolute Maximum Ratings	30
12	Recommended Operating Conditions	30
13	VDD_SPI Output Characteristics	30
14	DC Characteristics (3.3 V, 25 °C)	31
15	ADC Characteristics	31
16	Current Consumption Depending on RF Modes	32
17	Current Consumption Depending on Work Modes	32
18	Reliability Qualifications	32
19	Wi-Fi Frequency	33
20	TX Power with Spectral Mask and EVM Meeting 802.11 Standards	33
21	TX EVM Test	34
22	RX Sensitivity	34
23	Maximum RX Level	35
24	RX Adjacent Channel Rejection	35
25	Bluetooth LE Frequency	35
26	Transmitter Characteristics - Bluetooth LE 1 Mbps	36
27	Transmitter Characteristics - Bluetooth LE 2 Mbps	36
28	Transmitter Characteristics - Bluetooth LE 125 Kbps	36
29	Transmitter Characteristics - Bluetooth LE 500 Kbps	37
30	Receiver Characteristics - Bluetooth LE 1 Mbps	37
31	Receiver Characteristics - Bluetooth LE 2 Mbps	38
32	Receiver Characteristics - Bluetooth LE 125 Kbps	38
33	Receiver Characteristics - Bluetooth LE 500 Kbps	39

## List of Figures

1	Block Diagram of ESP32-C3	2
2	ESP32-C3 Series Nomenclature	9
3	ESP32-C3 Pin Layout (Top View)	10
4	ESP32-C3 Power Scheme	12
5	ESP32-C3 Power-up and Reset Timing	13
6	Setup and Hold Times for the Strapping Pins	14
7	Address Mapping Structure	17
8	QFN32 (5×5 mm) Package	40



# 1. ESP32-C3 Series Comparison

## 1.1 ESP32-C3 Series Nomenclature

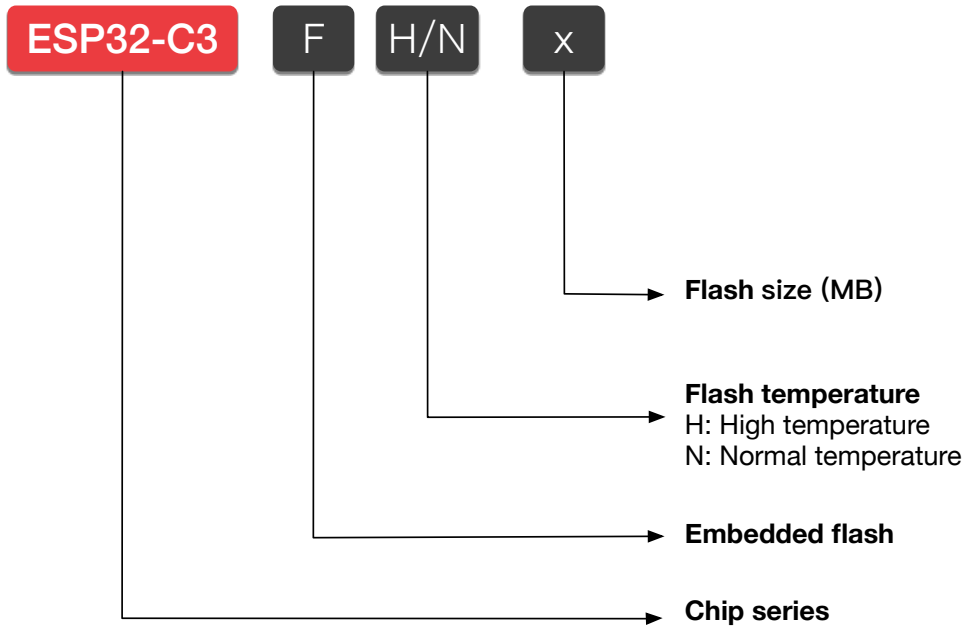

Figure 2: ESP32-C3 Series Nomenclature

## 1.2 Comparison

Table 1: ESP32-C3 Series Comparison

Ordering Code	Embedded Flash	Ambient Temperature (°C)	Package (mm)
ESP32-C3	—	-40 ~ 105	QFN32 (5*5)
ESP32-C3FN4	4 MB	-40 ~ 85	QFN32 (5*5)
ESP32-C3FH4	4 MB	-40 ~ 105	QFN32 (5*5)

## 2. Pin Definition

### 2.1 Pin Layout

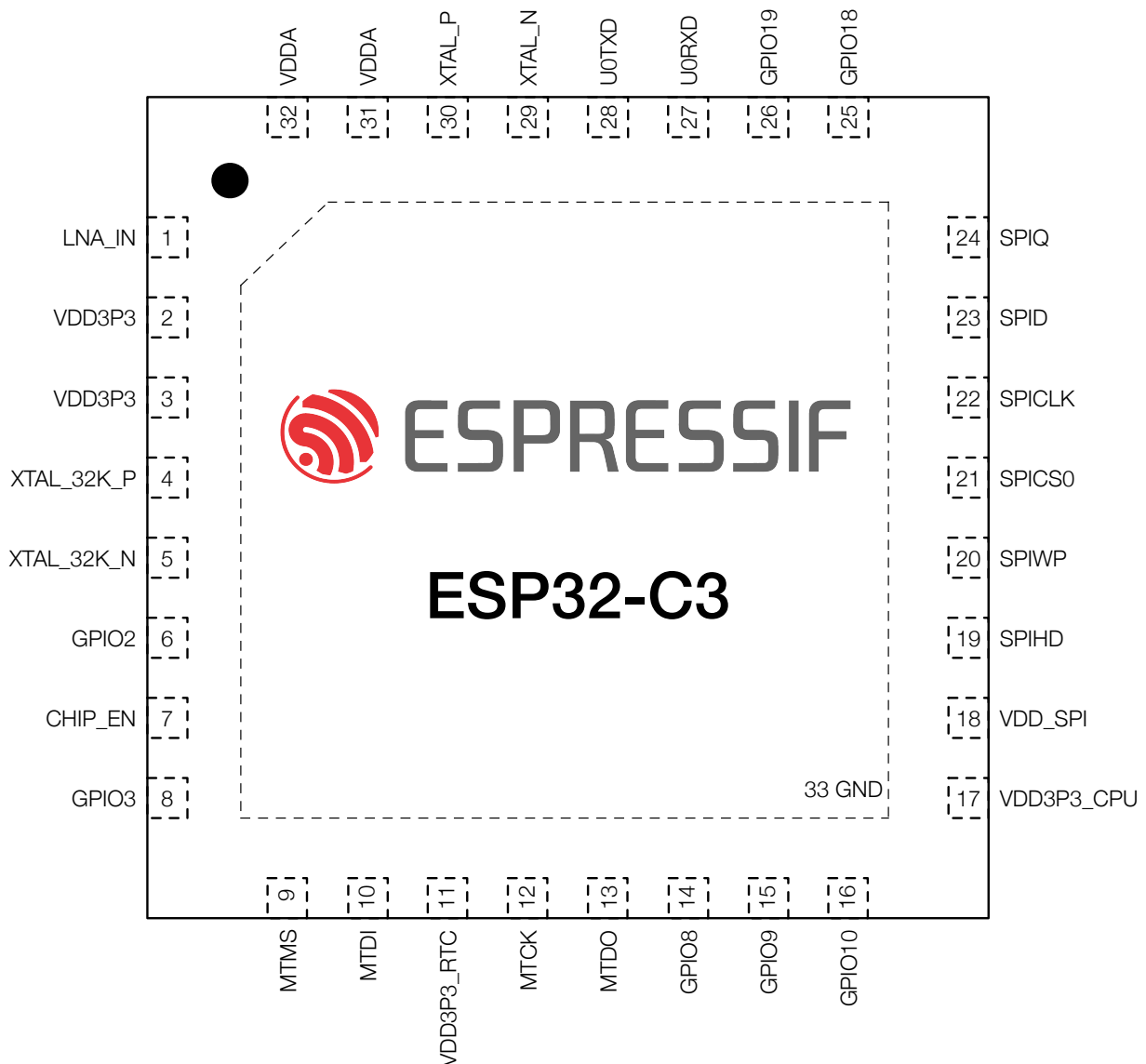

Figure 3: ESP32-C3 Pin Layout (Top View)

### 2.2 Pin Description

Table 2: Pin Description

Name	No.	Type	Power Domain	Function
LNA_IN	1	I/O	—	RF input and output
VDD3P3	2	P <sub>A</sub>	—	Analog power supply
VDD3P3	3	P <sub>A</sub>	—	Analog power supply
XTAL_32K_P	4	I/O/T	VDD3P3_RTC	<b>GPIO0</b> , ADC1_CH0, XTAL_32K_P
XTAL_32K_N	5	I/O/T	VDD3P3_RTC	<b>GPIO1</b> , ADC1_CH1, XTAL_32K_N
GPIO2	6	I/O/T	VDD3P3_RTC	<b>GPIO2</b> , ADC1_CH2, FSPIQ

Name	No.	Type	Power Domain	Function
CHIP_EN	7	I	VDD3P3_RTC	High: on, enables the chip. Low: off, the chip powers off. Note: Do not leave the CHIP_EN pin floating.
GPIO3	8	I/O/T	VDD3P3_RTC	<b>GPIO3</b> , ADC1_CH3
MTMS	9	I/O/T	VDD3P3_RTC	GPIO4, ADC1_CH4, FSPIHD, <b>MTMS</b>
MTDI	10	I/O/T	VDD3P3_RTC	GPIO5, ADC2_CH0, FSPIWP, <b>MTDI</b>
VDD3P3_RTC	11	P <sub>D</sub>	—	Input power supply for RTC
MTCK	12	I/O/T	VDD3P3_CPU	GPIO6, FSPICLK, <b>MTCK</b>
MTDO	13	I/O/T	VDD3P3_CPU	GPIO7, FSPID, <b>MTDO</b>
GPIO8	14	I/O/T	VDD3P3_CPU	<b>GPIO8</b>
GPIO9	15	I/O/T	VDD3P3_CPU	<b>GPIO9</b>
GPIO10	16	I/O/T	VDD3P3_CPU	<b>GPIO10</b> , FSPICS0
VDD3P3_CPU	17	P <sub>D</sub>	—	Input power supply for CPU IO
VDD_SPI	18	I/O/T/P <sub>D</sub>	VDD3P3_CPU	GPIO11, <b>output power supply for flash</b>
SPIHD	19	I/O/T	VDD3P3_CPU	<b>GPIO12</b> , SPIHD
SPIWP	20	I/O/T	VDD3P3_CPU	<b>GPIO13</b> , SPIWP
SPICS0	21	I/O/T	VDD3P3_CPU	GPIO14, <b>SPICS0</b>
SPICLK	22	I/O/T	VDD3P3_CPU	GPIO15, <b>SPICLK</b>
SPID	23	I/O/T	VDD3P3_CPU	GPIO16, <b>SPID</b>
SPIQ	24	I/O/T	VDD3P3_CPU	GPIO17, <b>SPIQ</b>
GPIO18	25	I/O/T	VDD3P3_CPU	GPIO18, <b>USB_D-</b>
GPIO19	26	I/O/T	VDD3P3_CPU	GPIO19, <b>USB_D+</b>
U0RXD	27	I/O/T	VDD3P3_CPU	GPIO20, <b>U0RXD</b>
U0TXD	28	I/O/T	VDD3P3_CPU	GPIO21, <b>U0TXD</b>
XTAL_N	29	—	—	External crystal output
XTAL_P	30	—	—	External crystal input
VDDA	31	P <sub>A</sub>	—	Analog power supply
VDDA	32	P <sub>A</sub>	—	Analog power supply
GND	33	G	—	Ground

<sup>1</sup> P<sub>A</sub>: analog power supply; P<sub>D</sub>: power supply for RTC IO; I: input; O: output; T: high impedance.

<sup>2</sup> Pin functions in bold font are the default pin functions in SPI boot mode.

<sup>3</sup> Ports of embedded flash correspond to pins of ESP32-C3FN4 and ESP32-C3FH4 as follows:

- CS# = SPICS0
- IO0/DI = SPID
- IO1/DO = SPIQ
- CLK = SPICLK
- IO2/WP# = SPIWP
- IO3/HOLD# = SPIHD

These pins are not recommended for other uses.

<sup>4</sup> For the data port connection between ESP32-C3 and external flash please refer to Section 3.4.2 *Serial Peripheral Interface (SPI)*.

<sup>5</sup> The pin function in this table refers only to some fixed settings and do not cover all cases for signals that can be input and output through the GPIO matrix. For more information on the GPIO matrix, please refer to Chapter IO MUX and GPIO Matrix (GPIO, IO\_MUX) in *ESP32-C3 Technical Reference Manual*.

## 2.3 Power Scheme

ESP32-C3 has four input power pins:

- VDDA1
- VDDA2
- VDD3P3\_RTC
- VDD3P3\_CPU

And one input/output power pin:

- VDD\_SPI

VDDA1 and VDDA2 are the input power supply for the analog domain.

When working as an output power supply, VDD\_SPI can be powered by VDD3P3\_CPU via  $R_{SPI}$  (nominal 3.3 V).

VDD\_SPI can be powered off via software to minimize the current leakage of flash in Deep-sleep mode.

RTC IO is powered from VDD3P3\_RTC.

The RTC domain is powered from Low Power Voltage Regulator, which is powered from VDD3P3\_RTC.

The Digital System domain is powered from Digital System Voltage Regulator, which is powered from VDD3P3\_CPU and VDD3P3\_RTC at the same time.

Digital IO is powered from VDD3P3\_CPU.

The power scheme diagram is shown in Figure 4.

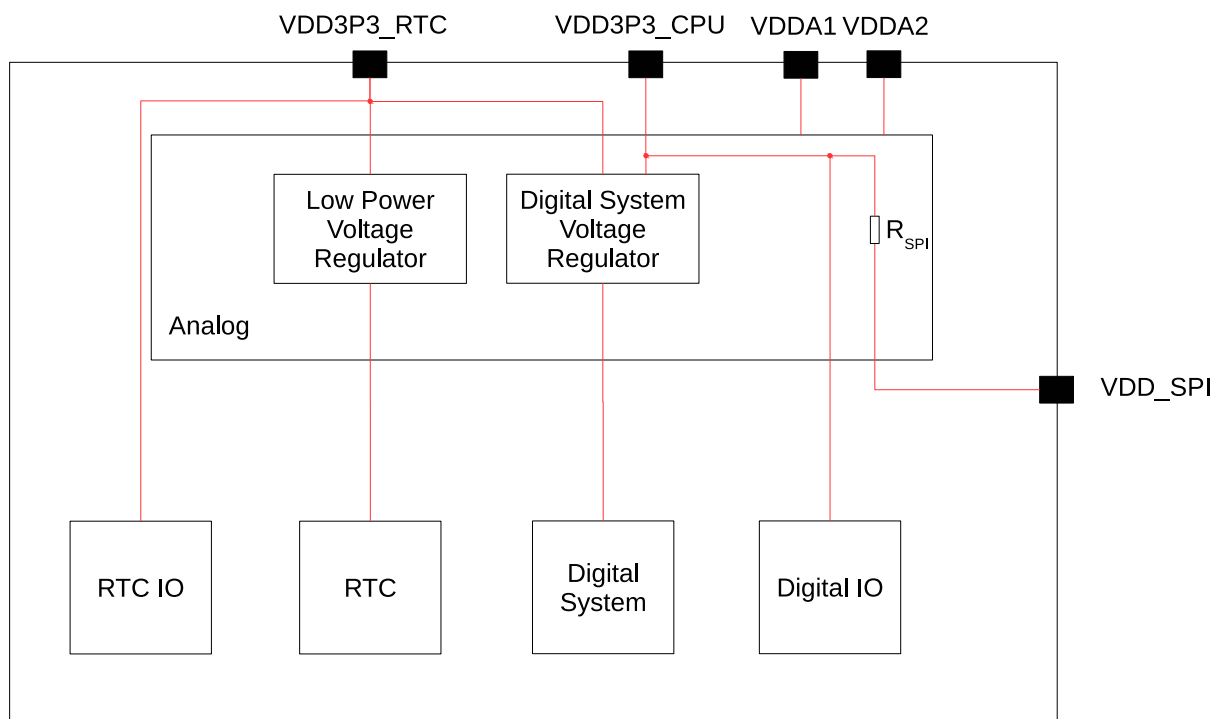

Figure 4: ESP32-C3 Power Scheme

### Notes on CHIP\_EN:

Figure 5 shows the power-up and reset timing of ESP32-C3. Details about the parameters are listed in Table

3.

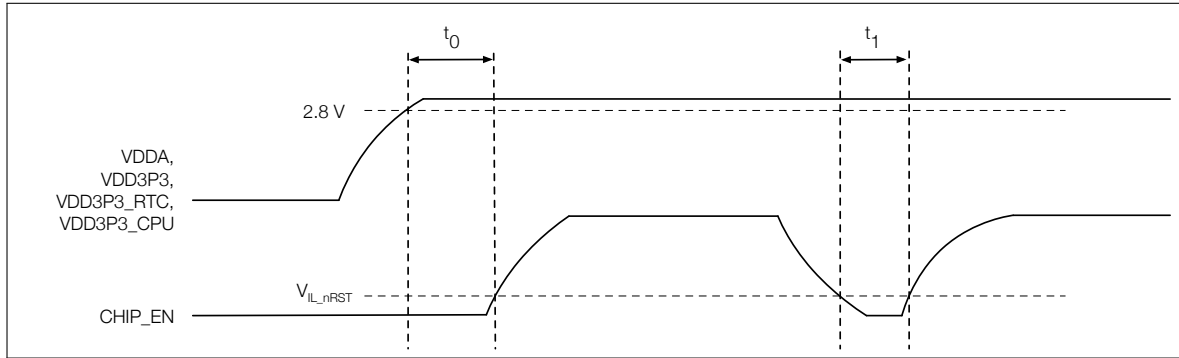

Figure 5: ESP32-C3 Power-up and Reset Timing

Table 3: Description of ESP32-C3 Power-up and Reset Timing Parameters

Parameter	Description	Min ( $\mu\text{s}$ )
$t_0$	Time between bringing up the VDDA, VDD3P3, VDD3P3_RTC, and VDD3P3_CPU rails, and activating CHIP_EN	50
$t_1$	Duration of CHIP_EN signal level $< V_{IL\_nRST}$ (refer to its value in Table 14) to reset the chip	50

## 2.4 Strapping Pins

ESP32-C3 has three strapping pins:

- GPIO2
- GPIO8
- GPIO9

Software can read the values of GPIO2, GPIO8 and GPIO9 from GPIO\_STRAPPING field in GPIO\_STRAP\_REG register. For register description, please refer to Section GPIO Matrix Register Summary in [ESP32-C3 Technical Reference Manual](#).

During the chip's system reset, the latches of the strapping pins sample the voltage level as strapping bits of "0" or "1", and hold these bits until the chip is powered down or shut down.

Types of system reset include:

- power-on reset
- RTC watchdog reset
- brownout reset
- analog super watchdog reset
- crystal clock glitch detection reset

By default, GPIO9 is connected to the internal weak pull-up resistor. If GPIO9 is not connected or connected to an external high-impedance circuit, the latched bit value will be "1"

To change the strapping bit values, you can apply the external pull-down/pull-up resistances, or use the host MCU's GPIOs to control the voltage level of these pins when powering on ESP32-C3.

After reset, the strapping pins work as normal-function pins.

Table 4 lists detailed booting configurations of the strapping pins.

**Table 4: Strapping Pins**

Booting Mode <sup>1</sup>			
Pin	Default	SPI Boot	Download Boot
GPIO2	N/A	1	1
GPIO8	N/A	Don't care	1
GPIO9	Internal weak pull-up	1	0
Enabling/Disabling ROM Messages Print During Booting			
Pin	Default	Functionality	
GPIO8	N/A	When the value of eFuse field EFUSE_UART_PRINT_CONTROL is 0 (default), print is enabled and not controlled by GPIO8. 1, if GPIO8 is 0, print is enabled; if GPIO8 is 1, it is disabled. 2, if GPIO8 is 0, print is disabled; if GPIO8 is 1, it is enabled. 3, print is disabled and not controlled by GPIO8.	

<sup>1</sup> The strapping combination of GPIO8 = 0 and GPIO9 = 0 is invalid and will trigger unexpected behavior.

Figure 6 shows the setup and hold times for the strapping pins before and after the CHIP\_EN signal goes high. Details about the parameters are listed in Table 5.

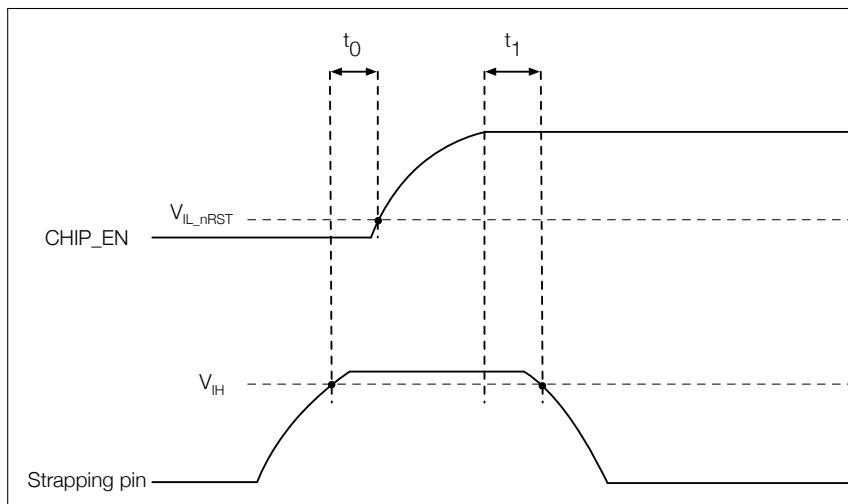

**Figure 6: Setup and Hold Times for the Strapping Pins**

**Table 5: Parameter Descriptions of Setup and Hold Times for the Strapping Pins**

<b>Parameter</b>	<b>Description</b>	<b>Min (ms)</b>
$t_0$	Setup time before CHIP_EN goes from low to high	0
$t_1$	Hold time after CHIP_EN goes high	3

## 3. Functional Description

This chapter describes the functions of ESP32-C3.

### 3.1 CPU and Memory

#### 3.1.1 CPU

ESP32-C3 has a low-power 32-bit RISC-V single-core microprocessor with the following features:

- four-stage pipeline that supports a clock frequency of up to 160 MHz
- RV32IMC ISA
- 32-bit multiplier and 32-bit divider
- up to 32 vectored interrupts at seven priority levels
- up to 8 hardware breakpoints/watchpoints
- up to 16 PMP regions
- JTAG for debugging

#### 3.1.2 Internal Memory

ESP32-C3's internal memory includes:

- **384 KB of ROM:** for booting and core functions.
- **400 KB of on-chip SRAM:** for data and instructions, running at a configurable frequency of up to 160 MHz. Of the 400 KB SRAM, 16 KB is configured for cache.
- **RTC FAST memory:** 8 KB of SRAM that can be accessed by the main CPU. It can retain data in Deep-sleep mode.
- **4 Kbit of eFuse:** 1792 bits are reserved for your data, such as encryption key and device ID.
- **Embedded flash :** See details in Chapter 1 [ESP32-C3 Series Comparison](#).

#### 3.1.3 External Flash

ESP32-C3 supports SPI, Dual SPI, Quad SPI, and QPI interfaces that allow connection to multiple external flash.

CPU's instruction memory space and read-only data memory space can map into external flash of ESP32-C3, whose size can be 16 MB at most. ESP32-C3 supports hardware encryption/decryption based on XTS-AES to protect developers' programs and data in flash.

Through high-speed caches, ESP32-C3 can support at a time up to:

- 8 MB of instruction memory space which can map into flash as individual blocks of 64 KB. 8-bit, 16-bit and 32-bit reads are supported.
- 8 MB of data memory space which can map into flash as individual blocks of 64 KB. 8-bit, 16-bit and 32-bit reads are supported.

**Note:**

After ESP32-C3 is initialized, software can customize the mapping of external flash into the CPU address space.



### 3.1.4 Address Mapping Structure

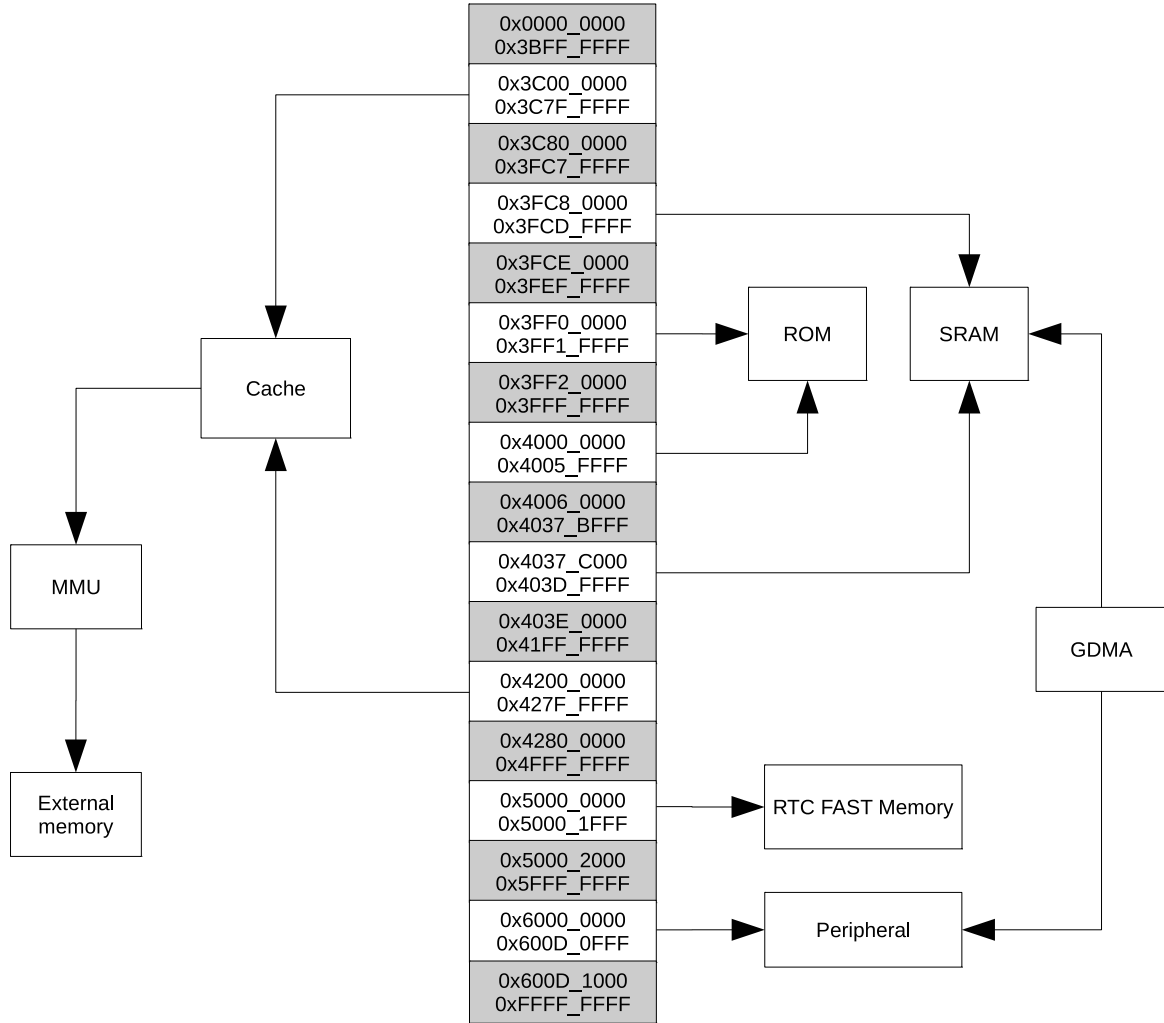

Figure 7: Address Mapping Structure

**Note:**

The memory space with gray background is not available for use.

### 3.1.5 Cache

ESP32-C3 has an eight-way set associative cache. This cache is read-only and has the following features:

- size: 16 KB
- block size: 32 bytes
- pre-load function
- lock function
- critical word first and early restart

## 3.2 System Clocks

### 3.2.1 CPU Clock

The CPU clock has three possible sources:

- external main crystal clock
- fast RC oscillator (typically about 17.5 MHz, and adjustable)
- PLL clock

The application can select the clock source from the three clocks above. The selected clock source drives the CPU clock directly, or after division, depending on the application. Once the CPU is reset, the default clock source would be the external main crystal clock divided by 2.

### 3.2.2 RTC Clock

The RTC slow clock is used for RTC counter, RTC watchdog and low-power controller. It has three possible sources:

- external low-speed (32 kHz) crystal clock
- internal slow RC oscillator (typically about 136 kHz, and adjustable)
- internal fast RC oscillator divided clock (derived from the fast RC oscillator divided by 256)

The RTC fast clock is used for RTC peripherals and sensor controllers. It has two possible sources:

- external main crystal clock divided by 2
- internal fast RC oscillator divide-by-N clock (typically about 17.5 MHz, and adjustable)

## 3.3 Analog Peripherals

### 3.3.1 Analog-to-Digital Converter (ADC)

ESP32-C3 integrates two 12-bit SAR ADCs.

- ADC1 supports measurements on 5 channels, and is factory-calibrated.
- ADC2 supports measurements on 1 channel, and is not factory-calibrated.

For ADC characteristics, please refer to Table 15.

### 3.3.2 Temperature Sensor

The temperature sensor generates a voltage that varies with temperature. The voltage is internally converted via an ADC into a digital value.

The temperature sensor has a range of  $-40\text{ }^{\circ}\text{C}$  to  $125\text{ }^{\circ}\text{C}$ . It is designed primarily to sense the temperature changes inside the chip. The temperature value depends on factors like microcontroller clock frequency or I/O load. Generally, the chip's internal temperature is higher than the operating ambient temperature.

## 3.4 Digital Peripherals

### 3.4.1 General Purpose Input / Output Interface (GPIO)

ESP32-C3 has 22 GPIO pins which can be assigned various functions by configuring corresponding registers. Besides digital signals, some GPIOs can be also used for analog functions, such as ADC.

All GPIOs have selectable internal pull-up or pull-down, or can be set to high impedance. When these GPIOs are configured as an input, the input value can be read by software through the register. Input GPIOs can also be set to generate edge-triggered or level-triggered CPU interrupts. All digital IO pins are bi-directional, non-inverting and tristate, including input and output buffers with tristate control. These pins can be multiplexed with other functions, such as the UART, SPI, etc. For low-power operations, the GPIOs can be set to holding state.

The IO MUX and the GPIO matrix are used to route signals from peripherals to GPIO pins. Together they provide highly configurable I/O. Using GPIO Matrix, peripheral input signals can be configured from any IO pins while peripheral output signals can be configured to any IO pins. Table 6 shows the IO MUX functions of each pin. For more information about IO MUX and GPIO matrix, please refer to Chapter IO MUX and GPIO Matrix (GPIO, IO\_MUX) in [ESP32-C3 Technical Reference Manual](#).

**Table 6: IO MUX Pin Functions**

Name	No.	Function 0	Function 1	Function 2	Reset	Notes
XTAL_32K_P	4	GPIO0	GPIO0	—	0	R
XTAL_32K_N	5	GPIO1	GPIO1	—	0	R
GPIO2	6	GPIO2	GPIO2	FSPIQ	1	R
GPIO3	8	GPIO3	GPIO3	—	1	R
MTMS	9	MTMS	GPIO4	FSPIHD	1	R
MTDI	10	MTDI	GPIO5	FSPIWP	1	R
MTCK	12	MTCK	GPIO6	FSPICK	1*	G
MTDO	13	MTDO	GPIO7	FSPID	1	G
GPIO8	14	GPIO8	GPIO8	—	1	—
GPIO9	15	GPIO9	GPIO9	—	3	—
GPIO10	16	GPIO10	GPIO10	FSPICS0	1	G
VDD_SPI	18	GPIO11	GPIO11	—	0	—
SPIHD	19	SPIHD	GPIO12	—	3	—
SPIWP	20	SPIWP	GPIO13	—	3	—
SPICS0	21	SPICS0	GPIO14	—	3	—
SPICLK	22	SPICLK	GPIO15	—	3	—
SPID	23	SPID	GPIO16	—	3	—
SPIQ	24	SPIQ	GPIO17	—	3	—
GPIO18	25	GPIO18	GPIO18	—	0	USB, G
GPIO19	26	GPIO19	GPIO19	—	0*	USB
U0RXD	27	U0RXD	GPIO20	—	3	G
U0TXD	28	U0TXD	GPIO21	—	4	—

### Reset

The default configuration of each pin after reset:

- **0** - input disabled, in high impedance state (IE = 0)
- **1** - input enabled, in high impedance state (IE = 1)
- **2** - input enabled, pull-down resistor enabled (IE = 1, WPD = 1)
- **3** - input enabled, pull-up resistor enabled (IE = 1, WPU = 1)
- **4** - output enabled, pull-up resistor enabled (OE = 1, WPU = 1)

- **0\*** - input disabled, pull-up resistor enabled (IE = 0, WPU = 0, USB\_WPU = 1). See details in Notes
- **1\*** - When the value of eFuse bit EFUSE\_DIS\_PAD\_JTAG is
  - 0, input enabled, pull-up resistor enabled (IE = 1, WPU = 1)
  - 1, input enabled, in high impedance state (IE = 1)

We recommend pulling high or low GPIO pins in high impedance state to avoid unnecessary power consumption. You may add pull-up and pull-down resistors in your PCB design referring to Table 14, or enable internal pull-up and pull-down resistors during software initialization.

#### Notes

- **R** - These pins have analog functions.
- **USB** - GPIO18 and GPIO19 are USB pins. The pull-up value of a USB pin is controlled by the pin's pull-up value together with USB pull-up value. If any of the two pull-up values is 1, the pin's pull-up resistor will be enabled. The pull-up resistors of USB pins are controlled by USB\_SERIAL\_JTAG\_DP\_PULLUP bit.
- **G** - These pins have glitches during power-up. See details in Table 7.

**Table 7: Power-Up Glitches on Pins**

Pin	Glitch <sup>1</sup>	Typical Time Period (ns)
MTCK	Low-level glitch	5
MTDO	Low-level glitch	5
GPIO10	Low-level glitch	5
U0RXD	Low-level glitch	5
GPIO18	Pull-up glitch	50000

<sup>1</sup> Low-level glitch: the pin is at a low level during the time period;  
 High-level glitch: the pin is at a high level during the time period;  
 Pull-up glitch: the pin is pulled up during the time period;  
 Pull-down glitch: the pin is pulled down during the time period.

### 3.4.2 Serial Peripheral Interface (SPI)

ESP32-C3 features three SPI interfaces (SPI0, SPI1, and SPI2). SPI0 and SPI1 can only be configured to operate in SPI memory mode, while SPI2 can be configured to operate in both SPI memory and general-purpose SPI modes.

- **SPI Memory mode**

In SPI memory mode, SPI0, SPI1 and SPI2 interface with external SPI memory. Data is transferred in bytes. Up to four-line STR reads and writes are supported. The clock frequency is configurable to a maximum of 120 MHz in STR mode.

- **SPI2 General-purpose SPI (GP-SPI) mode**

When SPI2 acts as a general-purpose SPI, it can operate in master and slave modes. SPI2 supports two-line full-duplex communication and single-/two-/four-line half-duplex communication in both master and slave modes. The host's clock frequency is configurable. Data is transferred in bytes. The clock polarity (CPOL) and phase (CPHA) are also configurable. The SPI2 interface can connect to GDMA.

- In master mode, the clock frequency is 80 MHz at most, and the four modes of SPI transfer format are supported.

- In slave mode, the clock frequency is 60 MHz at most, and the four modes of SPI transfer format are also supported.

The mapping between SPI bus signals and GPIO pins is shown in Table 8:

**Table 8: Mapping of SPI Signals and Chip Pads**

Full-Duplex SPI Signal	Half-Duplex SPI Signal	Chip Pin Signal	
		Pin Function	FSPI Signals
MOSI	MOSI	D	FSPID
MISO	(MISO)	Q	FSPIQ
CS	CS	CS	FSPICS0 ~ 5
CLK	CLK	CLK	FSPICLK
—	—	WP	FSPiWP
—	—	HD	FSPiHD

In most cases, the data port connection between ESP32-C3 and external flash is as follows:

**Table 9: Connection Between ESP32-C3 and External Flash**

Chip Pin	External Flash Data Port		
	SPI Single-Line Mode	SPI Two-Line Mode	SPI Four-Line Mode
SPID (SPID)	DI	IO0	IO0
SPIQ (SPIQ)	DO	IO1	IO1
SPIWP (SPIWP)	WP#	—	IO2
SPIHD (SPIHD)	HOLD#	—	IO3

### 3.4.3 Universal Asynchronous Receiver Transmitter (UART)

ESP32-C3 has two UART interfaces, i.e. UART0 and UART1, which support IrDA and asynchronous communication (RS232 and RS485) at a speed of up to 5 Mbps. The UART controller provides hardware flow control (CTS and RTS signals) and software flow control (XON and XOFF). Both UART interfaces connect to GDMA via UHCI0, and can be accessed by the GDMA controller or directly by the CPU.

### 3.4.4 I2C Interface

ESP32-C3 has an I2C bus interface which is used for I2C master mode or slave mode, depending on your configuration. The I2C interface supports:

- standard mode (100 Kbit/s)
- fast mode (400 Kbit/s)
- up to 800 Kbit/s (constrained by SCL and SDA pull-up strength)
- 7-bit and 10-bit addressing mode
- double addressing mode
- 7-bit broadcast address

You can configure instruction registers to control the I2C interface for more flexibility.

### 3.4.5 I2S Interface

ESP32-C3 includes a standard I2S interface. This interface can operate as a master or a slave in full-duplex mode or half-duplex mode, and can be configured for 8-bit, 16-bit, 24-bit, or 32-bit serial communication. BCK clock frequency, from 10 kHz up to 40 MHz, is supported.

The I2S interface supports TDM PCM, TDM MSB alignment, TDM standard, and PDM TX interface. It connects to the GDMA controller.

### 3.4.6 Remote Control Peripheral

The Remote Control Peripheral (RMT) supports two channels of infrared remote transmission and two channels of infrared remote reception. By controlling pulse waveform through software, it supports various infrared and other single wire protocols. All four channels share a 192 × 32-bit memory block to store transmit or receive waveform.

### 3.4.7 LED PWM Controller

The LED PWM controller can generate independent digital waveform on six channels. The LED PWM controller:

- can generate digital waveform with configurable periods and duty cycle. The accuracy of duty cycle can be up to 18 bits.
- has multiple clock sources, including APB clock and external main crystal clock.
- can operate when the CPU is in Light-sleep mode.
- supports gradual increase or decrease of duty cycle, which is useful for the LED RGB color-gradient generator.

### 3.4.8 General DMA Controller

ESP32-C3 has a general DMA controller (GDMA) with six independent channels, i.e. three transmit channels and three receive channels. These six channels are shared by peripherals with DMA feature. The GDMA controller implements a fixed-priority scheme among these channels, whose priority can be configured.

The GDMA controller controls data transfer using linked lists. It allows peripheral-to-memory and memory-to-memory data transfer at a high speed. All channels can access internal RAM.

Peripherals on ESP32-C3 with DMA feature are SPI2, UHCI0, I2S, AES, SHA, and ADC.

### 3.4.9 USB Serial/JTAG Controller

ESP32-C3 integrates a USB Serial/JTAG controller. This controller has the following features:

- USB 2.0 full speed compliant, capable of up to 12 Mbit/s transfer speed (Note that this controller does not support the faster 480 Mbit/s high-speed transfer mode)
- CDC-ACM virtual serial port and JTAG adapter functionality
- programming embedded/external flash
- CPU debugging with compact JTAG instructions
- a full-speed USB PHY integrated in the chip

### 3.4.10 TWAI<sup>®</sup> Controller

ESP32-C3 has a TWAI<sup>®</sup> controller with the following features:

- compatible with ISO 11898-1 protocol (CAN Specification 2.0)
- standard frame format (11-bit ID) and extended frame format (29-bit ID)
- bit rates from 1 Kbit/s to 1 Mbit/s
- multiple modes of operation: Normal, Listen Only, and Self-Test (no acknowledgment required)
- 64-byte receive FIFO
- acceptance filter (single and dual filter modes)
- error detection and handling: error counters, configurable error interrupt threshold, error code capture, arbitration lost capture

## 3.5 Radio and Wi-Fi

ESP32-C3 radio consists of the following blocks:

- 2.4 GHz receiver
- 2.4 GHz transmitter
- bias and regulators
- balun and transmit-receive switch
- clock generator

### 3.5.1 2.4 GHz Receiver

The 2.4 GHz receiver demodulates the 2.4 GHz RF signal to quadrature baseband signals and converts them to the digital domain with two high-resolution, high-speed ADCs. To adapt to varying signal channel conditions, ESP32-C3 integrates RF filters, Automatic Gain Control (AGC), DC offset cancelation circuits, and baseband filters.

### 3.5.2 2.4 GHz Transmitter

The 2.4 GHz transmitter modulates the quadrature baseband signals to the 2.4 GHz RF signal, and drives the antenna with a high-powered CMOS power amplifier. The use of digital calibration further improves the linearity of the power amplifier.

Additional calibrations are integrated to cancel any radio imperfections, such as:

- carrier leakage
- I/Q amplitude/phase matching
- baseband nonlinearities
- RF nonlinearities
- antenna matching

These built-in calibration routines reduce the cost, time, and specialized equipment required for product testing.

### 3.5.3 Clock Generator

The clock generator produces quadrature clock signals of 2.4 GHz for both the receiver and the transmitter. All components of the clock generator are integrated into the chip, including inductors, varactors, filters, regulators and dividers.

The clock generator has built-in calibration and self-test circuits. Quadrature clock phases and phase noise are optimized on chip with patented calibration algorithms which ensure the best performance of the receiver and the transmitter.

### 3.5.4 Wi-Fi Radio and Baseband

ESP32-C3 Wi-Fi radio and baseband support the following features:

- 802.11b/g/n
- 802.11n MCS0-7 that supports 20 MHz and 40 MHz bandwidth
- 802.11n MCS32
- 802.11n 0.4  $\mu$ s guard interval
- data rate up to 150 Mbps
- RX STBC (single spatial stream)
- adjustable transmitting power
- antenna diversity

ESP32-C3 supports antenna diversity with an external RF switch. This switch is controlled by one or more GPIOs, and used to select the best antenna to minimize the effects of channel imperfections.

### 3.5.5 Wi-Fi MAC

ESP32-C3 implements the full 802.11 b/g/n Wi-Fi MAC protocol. It supports the Basic Service Set (BSS) STA and SoftAP operations under the Distributed Control Function (DCF). Power management is handled automatically with minimal host interaction to minimize the active duty period.

ESP32-C3 Wi-Fi MAC applies the following low-level protocol functions automatically:

- 4  $\times$  virtual Wi-Fi interfaces
- infrastructure BSS in Station mode, SoftAP mode, Station + SoftAP mode, and promiscuous mode
- RTS protection, CTS protection, Immediate Block ACK
- fragmentation and defragmentation
- TX/RX A-MPDU, TX/RX A-MSDU
- transmit opportunity (TXOP)
- Wi-Fi multimedia (WMM)
- GCMP, CCMP, TKIP, WAPI, WEP, BIP, WPA2-PSK/WPA2-Enterprise, and WPA3-PSK/WPA3-Enterprise
- automatic beacon monitoring (hardware TSF)
- 802.11mc FTM



### 3.5.6 Networking Features

Espressif provides libraries for TCP/IP networking, ESP-WIFI-MESH networking, and other networking protocols over Wi-Fi. TLS 1.0, 1.1 and 1.2 is also supported.

## 3.6 Bluetooth LE

ESP32-C3 includes a Bluetooth Low Energy subsystem that integrates a hardware link layer controller, an RF/modem block and a feature-rich software protocol stack. It supports the core features of Bluetooth 5 and Bluetooth mesh.

### 3.6.1 Bluetooth LE Radio and PHY

Bluetooth Low Energy radio and PHY in ESP32-C3 support:

- 1 Mbps PHY
- 2 Mbps PHY for higher data rates
- coded PHY for longer range (125 Kbps and 500 Kbps)
- listen before talk (LBT), implemented in hardware
- antenna diversity with an external RF switch

This switch is controlled by one or more GPIOs, and used to select the best antenna to minimize the effects of channel imperfections.

### 3.6.2 Bluetooth LE Link Layer Controller

Bluetooth Low Energy Link Layer Controller in ESP32-C3 supports:

- LE advertising extensions, to enhance broadcasting capacity and broadcast more intelligent data
- multiple advertisement sets
- simultaneous advertising and scanning
- multiple connections in simultaneous central and peripheral roles
- adaptive frequency hopping and channel assessment
- LE channel selection algorithm #2
- connection parameter update
- high duty cycle non-connectable advertising
- LE privacy 1.2
- LE data packet length extension
- link layer extended scanner filter policies
- low duty cycle directed advertising
- link layer encryption
- LE Ping

## 3.7 Low Power Management

With the use of advanced power-management technologies, ESP32-C3 can switch between different power modes.

- Active mode: CPU and chip radio are powered on. The chip can receive, transmit, or listen.
- Modem-sleep mode: The CPU is operational and the clock speed can be reduced. Wi-Fi base band, Bluetooth LE base band, and radio are disabled, but Wi-Fi and Bluetooth LE connection can remain active.
- Light-sleep mode: The CPU is paused. Any wake-up events (MAC, host, RTC timer, or external interrupts) will wake up the chip. Wi-Fi and Bluetooth LE connection can remain active.
- Deep-sleep mode: CPU and most peripherals are powered down. Only the RTC memory is powered on. Wi-Fi connection data are stored in the RTC memory.

For power consumption in different power modes, please refer to Table 17.

## 3.8 Timers

### 3.8.1 General Purpose Timers

ESP32-C3 is embedded with two 54-bit general-purpose timers, which are based on 16-bit prescalers and 54-bit auto-reload-capable up/down-timers.

The timers' features are summarized as follows:

- a 16-bit clock prescaler, from 1 to 65536
- a 54-bit time-base counter programmable to be incrementing or decrementing
- able to read real-time value of the time-base counter
- halting and resuming the time-base counter
- programmable alarm generation
- level interrupt generation

### 3.8.2 System Timer

ESP32-C3 integrates a 52-bit system timer, which has two 52-bit counters and three comparators. The system timer has the following features:

- counters with a fixed clock frequency of 16 MHz
- three types of independent interrupts generated according to alarm value
- two alarm modes: target mode and period mode
- 52-bit target alarm value and 26-bit periodic alarm value
- automatic reload of counter value
- counters can be stalled if the CPU is stalled or in OCD mode

### 3.8.3 Watchdog Timers

ESP32-C3 contains three watchdog timers: one in each of the two timer groups (called Main System Watchdog Timers, or MWDT) and one in the RTC module (called the RTC Watchdog Timer, or RWDT).

During the flash boot process, RWDT and the MWDT in timer group 0 (TIMG0) are enabled automatically in order to detect and recover from booting errors.

Watchdog timers have the following features:

- four stages, each with a programmable timeout value. Each stage can be configured, enabled and disabled separately
- interrupt, CPU reset, or core reset for MWDT upon expiry of each stage; interrupt, CPU reset, core reset, or system reset for RWDT upon expiry of each stage
- 32-bit expiry counter
- write protection, to prevent RWDT and MWDT configuration from being altered inadvertently
- flash boot protection

If the boot process from an SPI flash does not complete within a predetermined period of time, the watchdog will reboot the entire main system.

### 3.9 Cryptographic Hardware Accelerators

ESP32-C3 is equipped with hardware accelerators of general algorithms, such as AES-128/AES-256 (FIPS PUB 197), ECB/CBC/OFB/CFB/CTR (NIST SP 800-38A), SHA1/SHA224/SHA256 (FIPS PUB 180-4), and RSA3072. The chip also supports independent arithmetic, such as Big Integer Multiplication and Big Integer Modular Multiplication. The maximum operation length for RSA and Big Integer Modular Multiplication is 3072 bits. The maximum factor length for Big Integer Multiplication is 1536 bits.

### 3.10 Physical Security Features

- Transparent external flash encryption (AES-XTS algorithm) with software inaccessible key prevents unauthorized readout of your application code or data.
- Secure boot feature uses a hardware root of trust to ensure only signed firmware (with RSA-PSS signature) can be booted.
- HMAC module can use a software inaccessible MAC key to generate MAC signatures for identity verification and other purposes.
- Digital Signature module can use a software inaccessible secure key to generate RSA signatures for identity verification.
- World Controller provides two running environments for software. All hardware and software resources are sorted to two groups, and placed in either secure or general world. The secure world cannot be accessed by hardware in the general world, thus establishing a security boundary.

### 3.11 Peripheral Pin Configurations

Table 10: Peripheral Pin Configurations

Interface	Signal	Pin	Function
ADC	ADC1_CH0	XTAL_32K_P	Two 12-bit SAR ADCs
	ADC1_CH1	XTAL_32K_N	
	ADC1_CH2	GPIO2	

Interface	Signal	Pin	Function		
	ADC1_CH3	GPIO3			
	ADC1_CH4	MTMS			
	ADC2_CH0	MTDI			
JTAG	MTDI	MTDI	JTAG for software debugging		
	MTCK	MTCK			
	MTMS	MTMS			
	MTDO	MTDO			
UART	U0RXD_in	Any GPIO pins	Two UART channels with hardware flow control and GDMA		
	U0CTS_in				
	U0DSR_in				
	U0TXD_out				
	U0RTS_out				
	U0DTR_out				
	U1RXD_in				
	U1CTS_in				
	U1DSR_in				
	U1TXD_out				
	U1RTS_out				
	U1DTR_out				
I2C	I2CEXT0_SCL_in			Any GPIO pins	One I2C channel in slave or master mode
	I2CEXT0_SDA_in				
	I2CEXT1_SCL_in				
	I2CEXT1_SDA_in				
	I2CEXT0_SCL_out				
	I2CEXT0_SDA_out				
	I2CEXT1_SCL_out				
	I2CEXT1_SDA_out				
LED PWM	ledc_ls_sig_out0~5	Any GPIO pins	Six independent PWM channels		
I2S	I2S0O_BCK_in	Any GPIO pins	Stereo input and output from/to the audiocodec		
	I2S_MCLK_in				
	I2SO_WS_in				
	I2SI_SD_in				
	I2SI_BCK_in				
	I2SI_WS_in				
	I2SO_BCK_out				
	I2S_MCLK_out				
	I2SO_WS_out				
	I2SO_SD_out				
	I2SI_BCK_out				
	I2SI_WS_out				
	I2SO_SD1_out				
Remote Control Peripheral	RMT_SIG_IN0~1			Any GPIO pins	Two channels for an IR transceiver of various waveforms
	RMT_SIG_OUT0~1				

Interface	Signal	Pin	Function
SPI0/1	SPICLK_out_mux	SPICLK	Support Standard SPI, Dual SPI, Quad SPI, and QPI that allow connection to external flash
	SPICS0_out	SPICS0	
	SPICS1_out	Any GPIO pins	
	SPID_in/_out	SPID	
	SPIQ_in/_out	SPIQ	
	SPIWP_in/_out	SPIWP	
	SPIHD_in/_out	SPIHD	
SPI2	FSPICLK_in/_out_mux	Any GPIO pins	<ul style="list-style-type: none"> <li>• Master mode and slave mode of SPI, Dual SPI, Quad SPI, and QPI</li> <li>• Connection to external flash, RAM, and other SPI devices</li> <li>• Four modes of SPI transfer format</li> <li>• Configurable SPI frequency</li> <li>• 64-byte FIFO or GDMA buffer</li> </ul>
	FSPICS0_in/_out		
	FSPICS1~5_out		
	FSPID_in/_out		
	FSPIQ_in/_out		
	FSPIWP_in/_out		
	FSPiHD_in/_out		
USB Serial/JTAG	USB_D+	GPIO19	USB-to-serial converter, and USB-to-JTAG converter
	USB_D-	GPIO18	
TWAI	twai_rx	Any GPIO pins	Compatible with ISO 11898-1 protocol
	twai_tx		
	twai_bus_off_on		
	twai_clkout		

## 4. Electrical Characteristics

### 4.1 Absolute Maximum Ratings

Stresses beyond the absolute maximum ratings listed in the table below may cause permanent damage to the device. These are stress ratings only, and do not refer to the functional operation of the device.

Table 11: Absolute Maximum Ratings

Symbol	Parameter	Min	Max	Unit
VDDA, VDD3P3, VDD3P3_RTC, VDD3P3_CPU, VDD_SPI	Voltage applied to power supply pins per power domain	-0.3	3.6	V
T <sub>STORE</sub>	Storage temperature	-40	150	°C

### 4.2 Recommended Operating Conditions

Table 12: Recommended Operating Conditions

Symbol	Parameter	Min	Typ	Max	Unit
VDDA, VDD3P3 VDD3P3_RTC	Voltage applied to power supply pins per power domain	3.0	3.3	3.6	V
VDD_SPI (working as input power supply) <sup>1</sup>	—	3.0	3.3	3.6	V
VDD3P3_CPU <sup>2,3</sup>	Voltage applied to power supply pin	3.0	3.3	3.6	V
I <sub>VDD</sub> <sup>4</sup>	Current delivered by external power supply	0.5	—	—	A
T <sub>A</sub>	Operating ambient temperature	-40	—	105	°C
				85	
				105	

<sup>1</sup> For more information, please refer to Section 2.3 *Power Scheme*.

<sup>2</sup> When VDD\_SPI is used to drive peripherals, VDD3P3\_CPU should comply with the peripherals' specifications. For more information, please refer to Table 13.

<sup>3</sup> To write eFuse, VDD3P3\_CPU should not be higher than 3.3 V.

<sup>4</sup> If you use a single power supply, the recommended output current is 500 mA or more.

### 4.3 VDD\_SPI Output Characteristics

Table 13: VDD\_SPI Output Characteristics

Symbol	Parameter	Typ	Unit
R <sub>SPI</sub>	On-resistance in 3.3 V mode	7.5	Ω

**Note:**

In real-life applications, when VDD\_SPI works in 3.3 V output mode, VDD3P3\_CPU may be affected by  $R_{SPI}$ . For example, when VDD3P3\_CPU is used to drive a 3.3 V flash, it should comply with the following specifications:

$$VDD3P3\_CPU > VDD\_flash\_min + I\_flash\_max * R_{SPI}$$

Among which, VDD\_flash\_min is the minimum operating voltage of the flash, and I\_flash\_max the maximum current.

For more information, please refer to section [2.3 Power Scheme](#).

## 4.4 DC Characteristics (3.3 V, 25 °C)

Table 14: DC Characteristics (3.3 V, 25 °C)

Symbol	Parameter	Min	Typ	Max	Unit
$C_{IN}$	Pin capacitance	—	2	—	pF
$V_{IH}$	High-level input voltage	$0.75 \times VDD^1$	—	$VDD^1 + 0.3$	V
$V_{IL}$	Low-level input voltage	-0.3	—	$0.25 \times VDD^1$	V
$I_{IH}$	High-level input current	—	—	50	nA
$I_{IL}$	Low-level input current	—	—	50	nA
$V_{OH}^2$	High-level output voltage	$0.8 \times VDD^1$	—	—	V
$V_{OL}^2$	Low-level output voltage	—	—	$0.1 \times VDD^1$	V
$I_{OH}$	High-level source current (VDD <sup>1</sup> = 3.3 V, $V_{OH} \geq 2.64$ V, PAD_DRIVER = 3)	—	40	—	mA
$I_{OL}$	Low-level sink current (VDD <sup>1</sup> = 3.3 V, $V_{OL} = 0.495$ V, PAD_DRIVER = 3)	—	28	—	mA
$R_{PU}$	Pull-up resistor	—	45	—	k $\Omega$
$R_{PD}$	Pull-down resistor	—	45	—	k $\Omega$
$V_{IH\_nRST}$	Chip reset release voltage	$0.75 \times VDD^1$	—	$VDD^1 + 0.3$	V
$V_{IL\_nRST}$	Chip reset voltage	-0.3	—	$0.25 \times VDD^1$	V

<sup>1</sup> VDD is the I/O voltage for a particular power domain of pins.

<sup>2</sup>  $V_{OH}$  and  $V_{OL}$  are measured using high-impedance load.

## 4.5 ADC Characteristics

Table 15: ADC Characteristics

Symbol	Parameter	Min	Max	Unit
DNL (Differential nonlinearity) <sup>1</sup>	ADC connected to an external 100 nF capacitor; DC signal input; ambient temperature at 25 °C; Wi-Fi off	-7	7	LSB
INL (Integral nonlinearity)		-12	12	LSB
Sampling rate	—	—	100	kSPS <sup>2</sup>
Effective Range	ATTEN0	0	750	mV
	ATTEN1	0	1050	mV
	ATTEN2	0	1300	mV
	ATTEN3	0	2500	mV

<sup>1</sup> To get better DNL results, you can sample multiple times and apply a filter, or calculate the average value.

<sup>2</sup> kSPS means kilo samples-per-second.

## 4.6 Current Consumption

The current consumption measurements are taken with a 3.3 V supply at 25 °C of ambient temperature at the RF port. All transmitters' measurements are based on a 100% duty cycle.

**Table 16: Current Consumption Depending on RF Modes**

Work mode	Description		Peak (mA)
Active (RF working)	TX	802.11b, 1 Mbps, @21 dBm	335
		802.11g, 54 Mbps, @19 dBm	285
		802.11n, HT20, MCS7, @18.5 dBm	276
		802.11n, HT40, MCS7, @18.5 dBm	278
	RX	802.11b/g/n, HT20	84
		802.11n, HT40	87

**Table 17: Current Consumption Depending on Work Modes**

Work mode	Description	Typ	Unit
Modem-sleep <sup>1, 2</sup>	The CPU is powered on <sup>3</sup>	160 MHz	20 mA
		80 MHz	15 mA
Light-sleep	—	130	μA
Deep-sleep	RTC timer + RTC memory	5	μA
Power off	CHIP_PU is set to low level, the chip is powered off	1	μA

<sup>1</sup> The current consumption figures in Modem-sleep mode are for cases where the CPU is powered on and the cache idle.

<sup>2</sup> When Wi-Fi is enabled, the chip switches between Active and Modem-sleep modes. Therefore, current consumption changes accordingly.

<sup>3</sup> In Modem-sleep mode, the CPU frequency changes automatically. The frequency depends on the CPU load and the peripherals used.

## 4.7 Reliability

**Table 18: Reliability Qualifications**

Test Item	Test Conditions	Test Standard
HTOL (High Temperature Operating Life)	125 °C, 1000 hours	JESD22-A108
ESD (Electro-Static Discharge Sensitivity)	HBM (Human Body Mode) <sup>1</sup> ± 2000 V	JS-001
	CDM (Charge Device Mode) <sup>2</sup> ± 1000 V	JS-002
Latch up	Current trigger ± 200 mA	JESD78
	Voltage trigger $1.5 \times VDD_{max}$	

Cont'd on next page



Table 18 – cont'd from previous page

Test Item	Test Conditions	Test Standard
Preconditioning	Bake 24 hours @125 °C Moisture soak (level 3: 192 hours @30 °C, 60% RH) IR reflow solder: 260 + 0 °C, 20 seconds, three times	J-STD-020, JESD47, JESD22-A113
TCT (Temperature Cycling Test)	–65 °C / 150 °C, 500 cycles	JESD22-A104
uHAST (Highly Accelerated Stress Test, unbiased)	130 °C, 85% RH, 96 hours	JESD22-A118
HTSL (High Temperature Storage Life)	150 °C, 1000 hours	JESD22-A103
LTSL (Low Temperature Storage Life)	– 40 °C, 1000 hours	JESD22-A119

<sup>1</sup> JEDEC document JEP155 states that 500 V HBM allows safe manufacturing with a standard ESD control process.

<sup>2</sup> JEDEC document JEP157 states that 250 V CDM allows safe manufacturing with a standard ESD control process.

## 4.8 Wi-Fi Radio

Table 19: Wi-Fi Frequency

Parameter	Min (MHz)	Typ (MHz)	Max (MHz)
Center frequency of operating channel	2412	—	2484

### 4.8.1 Wi-Fi RF Transmitter (TX) Specifications

Table 20: TX Power with Spectral Mask and EVM Meeting 802.11 Standards

Rate	Min (dBm)	Typ (dBm)	Max (dBm)
802.11b, 1 Mbps	—	21.0	—
802.11b, 11 Mbps	—	21.0	—
802.11g, 6 Mbps	—	21.0	—
802.11g, 54 Mbps	—	19.0	—
802.11n, HT20, MCS0	—	20.0	—
802.11n, HT20, MCS7	—	18.5	—
802.11n, HT40, MCS0	—	20.0	—
802.11n, HT40, MCS7	—	18.5	—

Table 21: TX EVM Test

Rate	Min (dB)	Typ (dB)	SL <sup>1</sup> (dB)
802.11b, 1 Mbps, @21 dBm	—	-24.5	-10
802.11b, 11 Mbps, @21 dBm	—	-25.0	-10
802.11g, 6 Mbps, @21 dBm	—	-23.0	-5
802.11g, 54 Mbps, @19 dBm	—	-27.5	-25
802.11n, HT20, MSC0, @20 dBm	—	-22.5	-5
802.11n, HT20, MSC7, @18.5 dBm	—	-29.0	-27
802.11n, HT40, MSC0, @20 dBm	—	-22.5	-5
802.11n, HT40, MSC7, @18.5 dBm	—	-28.0	-27

<sup>1</sup> SL stands for standard limit value.

## 4.8.2 Wi-Fi RF Receiver (RX) Specifications

Table 22: RX Sensitivity

Rate	Min (dBm)	Typ (dBm)	Max (dBm)
802.11b, 1 Mbps	—	-98.4	—
802.11b, 2 Mbps	—	-96.0	—
802.11b, 5.5 Mbps	—	-93.0	—
802.11b, 11 Mbps	—	-88.6	—
802.11g, 6 Mbps	—	-93.8	—
802.11g, 9 Mbps	—	-92.2	—
802.11g, 12 Mbps	—	-91.0	—
802.11g, 18 Mbps	—	-88.4	—
802.11g, 24 Mbps	—	-85.8	—
802.11g, 36 Mbps	—	-82.0	—
802.11g, 48 Mbps	—	-78.0	—
802.11g, 54 Mbps	—	-76.6	—
802.11n, HT20, MCS0	—	-93.6	—
802.11n, HT20, MCS1	—	-90.8	—
802.11n, HT20, MCS2	—	-88.4	—
802.11n, HT20, MCS3	—	-85.0	—
802.11n, HT20, MCS4	—	-81.8	—
802.11n, HT20, MCS5	—	-77.8	—
802.11n, HT20, MCS6	—	-76.0	—
802.11n, HT20, MCS7	—	-74.8	—
802.11n, HT40, MCS0	—	-90.0	—
802.11n, HT40, MCS1	—	-88.0	—
802.11n, HT40, MCS2	—	-85.2	—
802.11n, HT40, MCS3	—	-82.0	—
802.11n, HT40, MCS4	—	-78.8	—

Cont'd on next page

Table 22 – cont'd from previous page

Rate	Min (dBm)	Typ (dBm)	Max (dBm)
802.11n, HT40, MCS5	—	-74.6	—
802.11n, HT40, MCS6	—	-73.0	—
802.11n, HT40, MCS7	—	-71.4	—

Table 23: Maximum RX Level

Rate	Min (dBm)	Typ (dBm)	Max (dBm)
802.11b, 1 Mbps	—	5	—
802.11b, 11 Mbps	—	5	—
802.11g, 6 Mbps	—	5	—
802.11g, 54 Mbps	—	0	—
802.11n, HT20, MCS0	—	5	—
802.11n, HT20, MCS7	—	0	—
802.11n, HT40, MCS0	—	5	—
802.11n, HT40, MCS7	—	0	—

Table 24: RX Adjacent Channel Rejection

Rate	Min (dB)	Typ (dB)	Max (dB)
802.11b, 1 Mbps	—	35	—
802.11b, 11 Mbps	—	35	—
802.11g, 6 Mbps	—	31	—
802.11g, 54 Mbps	—	20	—
802.11n, HT20, MSC0	—	31	—
802.11n, HT20, MSC7	—	16	—
802.11n, HT40, MSC0	—	25	—
802.11n, HT40, MSC7	—	11	—

## 4.9 Bluetooth LE Radio

Table 25: Bluetooth LE Frequency

Parameter	Min (MHz)	Typ (MHz)	Max (MHz)
Center frequency of operating channel	2402	—	2480

### 4.9.1 Bluetooth LE RF Transmitter (TX) Specifications

Table 26: Transmitter Characteristics - Bluetooth LE 1 Mbps

Parameter	Description	Min	Typ	Max	Unit
RF transmit power	RF power control range	-27.00	0	18.00	dBm
	Gain control step	—	3.00	—	dB
Carrier frequency offset and drift	Max $ f_n _{n=0, 1, 2, \dots, k}$	—	17.00	—	kHz
	Max $ f_0 - f_n $	—	1.75	—	kHz
	Max $ f_n - f_{n-5} $	—	1.46	—	kHz
	$ f_1 - f_0 $	—	0.80	—	kHz
Modulation characteristics	$\Delta f_{1\text{avg}}$	—	250.00	—	kHz
	Min $\Delta f_{2\text{max}}$ (for at least 99.9% of all $\Delta f_{2\text{max}}$ )	—	190.00	—	kHz
	$\Delta f_{2\text{avg}}/\Delta f_{1\text{avg}}$	—	0.83	—	—
In-band spurious emissions	$\pm 2$ MHz offset	—	-37.62	—	dBm
	$\pm 3$ MHz offset	—	-41.95	—	dBm
	$\pm > 3$ MHz offset	—	-44.48	—	dBm

Table 27: Transmitter Characteristics - Bluetooth LE 2 Mbps

Parameter	Description	Min	Typ	Max	Unit
RF transmit power	RF power control range	-27.00	0	18.00	dBm
	Gain control step	—	3.00	—	dB
Carrier frequency offset and drift	Max $ f_n _{n=0, 1, 2, \dots, k}$	—	20.80	—	kHz
	Max $ f_0 - f_n $	—	1.30	—	kHz
	Max $ f_n - f_{n-5} $	—	1.33	—	kHz
	$ f_1 - f_0 $	—	0.70	—	kHz
Modulation characteristics	$\Delta f_{1\text{avg}}$	—	498.00	—	kHz
	Min $\Delta f_{2\text{max}}$ (for at least 99.9% of all $\Delta f_{2\text{max}}$ )	—	430.00	—	kHz
	$\Delta f_{2\text{avg}}/\Delta f_{1\text{avg}}$	—	0.93	—	—
In-band spurious emissions	$\pm 4$ MHz offset	—	-43.55	—	dBm
	$\pm 5$ MHz offset	—	-45.26	—	dBm
	$\pm > 5$ MHz offset	—	-45.26	—	dBm

Table 28: Transmitter Characteristics - Bluetooth LE 125 Kbps

Parameter	Description	Min	Typ	Max	Unit
RF transmit power	RF power control range	-27.00	0	18.00	dBm
	Gain control step	—	3.00	—	dB
Carrier frequency offset and drift	Max $ f_n _{n=0, 1, 2, \dots, k}$	—	17.50	—	kHz
	Max $ f_0 - f_n $	—	0.45	—	kHz
	$ f_n - f_{n-3} $	—	0.70	—	kHz
	$ f_0 - f_3 $	—	0.30	—	kHz

Cont'd on next page

Table 28 – cont'd from previous page

Parameter	Description	Min	Typ	Max	Unit
Modulation characteristics	$\Delta f_{1_{avg}}$	—	250.00	—	kHz
	Min $\Delta f_{1_{max}}$ (for at least 99.9% of all $\Delta f_{2_{max}}$ )	—	235.00	—	kHz
In-band spurious emissions	$\pm 2$ MHz offset	—	-37.90	—	dBm
	$\pm 3$ MHz offset	—	-41.00	—	dBm
	$\pm > 3$ MHz offset	—	-42.50	—	dBm

Table 29: Transmitter Characteristics - Bluetooth LE 500 Kbps

Parameter	Description	Min	Typ	Max	Unit
RF transmit power	RF power control range	-27.00	0	18.00	dBm
	Gain control step	—	3.00	—	dB
Carrier frequency offset and drift	Max $ f_n _{n=0, 1, 2, \dots, k}$	—	17.00	—	kHz
	Max $ f_0 - f_n $	—	0.88	—	kHz
	$ f_n - f_{n-3} $	—	1.00	—	kHz
	$ f_0 - f_3 $	—	0.20	—	kHz
Modulation characteristics	$\Delta f_{2_{avg}}$	—	208.00	—	kHz
	Min $\Delta f_{2_{max}}$ (for at least 99.9% of all $\Delta f_{2_{max}}$ )	—	190.00	—	kHz
In-band spurious emissions	$\pm 2$ MHz offset	—	-37.90	—	dBm
	$\pm 3$ MHz offset	—	-41.30	—	dBm
	$\pm > 3$ MHz offset	—	-42.80	—	dBm

## 4.9.2 Bluetooth LE RF Receiver (RX) Specifications

Table 30: Receiver Characteristics - Bluetooth LE 1 Mbps

Parameter	Description	Min	Typ	Max	Unit
Sensitivity @30.8% PER	—	—	-97	—	dBm
Maximum received signal @30.8% PER	—	—	5	—	dBm
Co-channel C/I	—	—	8	—	dB
Adjacent channel selectivity C/I	F = F <sub>0</sub> + 1 MHz	—	-3	—	dB
	F = F <sub>0</sub> - 1 MHz	—	-4	—	dB
	F = F <sub>0</sub> + 2 MHz	—	-29	—	dB
	F = F <sub>0</sub> - 2 MHz	—	-31	—	dB
	F = F <sub>0</sub> + 3 MHz	—	-33	—	dB
	F = F <sub>0</sub> - 3 MHz	—	-27	—	dB
	F ≥ F <sub>0</sub> + 4 MHz	—	-29	—	dB
	F ≤ F <sub>0</sub> - 4 MHz	—	-38	—	dB
Image frequency	—	—	-29	—	dB
Adjacent channel to image frequency	F = F <sub>image</sub> + 1 MHz	—	-41	—	dB
	F = F <sub>image</sub> - 1 MHz	—	-33	—	dB

Cont'd on next page

Table 30 – cont'd from previous page

Parameter	Description	Min	Typ	Max	Unit
Out-of-band blocking performance	30 MHz ~ 2000 MHz	—	-5	—	dBm
	2003 MHz ~ 2399 MHz	—	-18	—	dBm
	2484 MHz ~ 2997 MHz	—	-15	—	dBm
	3000 MHz ~ 12.75 GHz	—	-5	—	dBm
Intermodulation	—	—	-30	—	dBm

Table 31: Receiver Characteristics - Bluetooth LE 2 Mbps

Parameter	Description	Min	Typ	Max	Unit
Sensitivity @30.8% PER	—	—	-93	—	dBm
Maximum received signal @30.8% PER	—	—	3	—	dBm
Co-channel C/I	—	—	10	—	dB
Adjacent channel selectivity C/I	$F = F_0 + 2 \text{ MHz}$	—	-7	—	dB
	$F = F_0 - 2 \text{ MHz}$	—	-7	—	dB
	$F = F_0 + 4 \text{ MHz}$	—	-28	—	dB
	$F = F_0 - 4 \text{ MHz}$	—	-26	—	dB
	$F = F_0 + 6 \text{ MHz}$	—	-26	—	dB
	$F = F_0 - 6 \text{ MHz}$	—	-27	—	dB
	$F \geq F_0 + 8 \text{ MHz}$	—	-29	—	dB
$F \leq F_0 - 8 \text{ MHz}$	—	-28	—	dB	
Image frequency	—	—	-28	—	dB
Adjacent channel to image frequency	$F = F_{image} + 2 \text{ MHz}$	—	-26	—	dB
	$F = F_{image} - 2 \text{ MHz}$	—	-7	—	dB
Out-of-band blocking performance	30 MHz ~ 2000 MHz	—	-5	—	dBm
	2003 MHz ~ 2399 MHz	—	-19	—	dBm
	2484 MHz ~ 2997 MHz	—	-16	—	dBm
	3000 MHz ~ 12.75 GHz	—	-5	—	dBm
Intermodulation	—	—	-29	—	dBm

Table 32: Receiver Characteristics - Bluetooth LE 125 Kbps

Parameter	Description	Min	Typ	Max	Unit
Sensitivity @30.8% PER	—	—	-105	—	dBm
Maximum received signal @30.8% PER	—	—	5	—	dBm
Co-channel C/I	—	—	3	—	dB
Adjacent channel selectivity C/I	$F = F_0 + 1 \text{ MHz}$	—	-6	—	dB
	$F = F_0 - 1 \text{ MHz}$	—	-6	—	dB
	$F = F_0 + 2 \text{ MHz}$	—	-33	—	dB
	$F = F_0 - 2 \text{ MHz}$	—	-43	—	dB
	$F = F_0 + 3 \text{ MHz}$	—	-37	—	dB
	$F = F_0 - 3 \text{ MHz}$	—	-47	—	dB
	$F \geq F_0 + 4 \text{ MHz}$	—	-40	—	dB
	$F \leq F_0 - 4 \text{ MHz}$	—	-50	—	dB

Cont'd on next page

Table 32 – cont'd from previous page

Parameter	Description	Min	Typ	Max	Unit
Image frequency	—	—	-40	—	dB
Adjacent channel to image frequency	$F = F_{image} + 1 \text{ MHz}$	—	-50	—	dB
	$F = F_{image} - 1 \text{ MHz}$	—	-37	—	dB

Table 33: Receiver Characteristics - Bluetooth LE 500 Kbps

Parameter	Description	Min	Typ	Max	Unit
Sensitivity @30.8% PER	—	—	-100	—	dBm
Maximum received signal @30.8% PER	—	—	5	—	dBm
Co-channel C/I	—	—	3	—	dB
Adjacent channel selectivity C/I	$F = F_0 + 1 \text{ MHz}$	—	-2	—	dB
	$F = F_0 - 1 \text{ MHz}$	—	-3	—	dB
	$F = F_0 + 2 \text{ MHz}$	—	-32	—	dB
	$F = F_0 - 2 \text{ MHz}$	—	-33	—	dB
	$F = F_0 + 3 \text{ MHz}$	—	-23	—	dB
	$F = F_0 - 3 \text{ MHz}$	—	-40	—	dB
	$F \geq F_0 + 4 \text{ MHz}$	—	-34	—	dB
$F \leq F_0 - 4 \text{ MHz}$	—	-44	—	dB	
Image frequency	—	—	-34	—	dB
Adjacent channel to image frequency	$F = F_{image} + 1 \text{ MHz}$	—	-46	—	dB
	$F = F_{image} - 1 \text{ MHz}$	—	-23	—	dB

## 5. Package Information

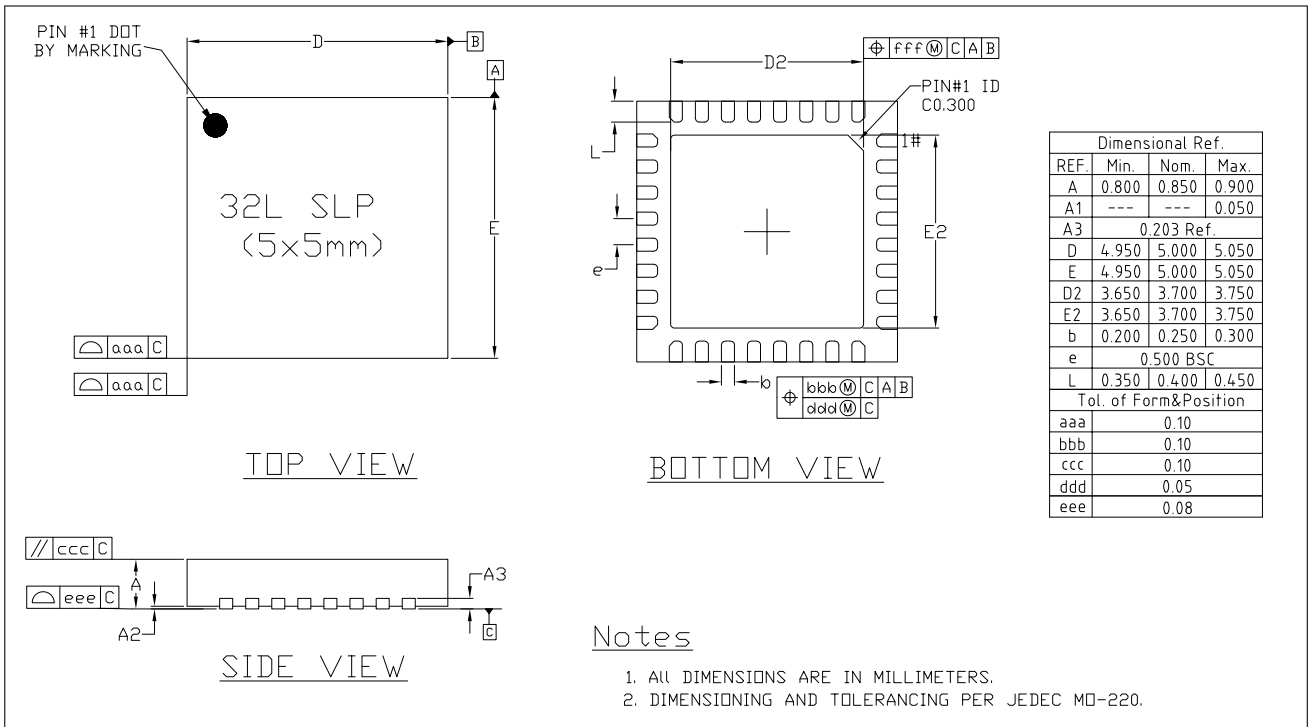

Figure 8: QFN32 (5x5 mm) Package

**Note:**

- For the source file of [recommended PCB land pattern](#) (dxf), you can view it with [Autodesk Viewer](#);
- For information about tape, reel, and product marking, please refer to [Espressif Chip-Packing Information](#).



## 6. Related Documentation and Resources

### Related Documentation

- [ESP32-C3 Technical Reference Manual](#) – Detailed information on how to use the ESP32-C3 memory and peripherals.
- *Certificates*  
<http://espressif.com/en/support/documents/certificates>
- *Documentation Updates and Update Notification Subscription*  
<http://espressif.com/en/support/download/documents>

### Developer Zone

- [ESP-IDF Programming Guide for ESP32-C3](#) – Extensive documentation for the ESP-IDF development framework.
- *ESP-IDF* and other development frameworks on GitHub.  
<http://github.com/espressif>
- *ESP32 BBS Forum* – Engineer-to-Engineer (E2E) Community for Espressif products where you can post questions, share knowledge, explore ideas, and help solve problems with fellow engineers.  
<http://esp32.com/>
- *The ESP Journal* – Best Practices, Articles, and Notes from Espressif folks.  
<http://blog.espressif.com/>
- See the tabs *SDKs and Demos*, *Apps*, *Tools*, *AT Firmware*.  
<http://espressif.com/en/support/download/sdks-demos>

### Products

- *ESP32-C3 Series SoCs* – Browse through all ESP32-C3 SoCs.  
<http://espressif.com/en/products/socs?id=ESP32-C3>
- *ESP32-C3 Series Modules* – Browse through all ESP32-C3-based modules.  
<http://espressif.com/en/products/modules?id=ESP32-C3>
- *ESP32-C3 Series DevKits* – Browse through all ESP32-C3-based devkits.  
<http://espressif.com/en/products/devkits?id=ESP32-C3>
- *ESP Product Selector* – Find an Espressif hardware product suitable for your needs by comparing or applying filters.  
<http://products.espressif.com/#/product-selector?language=en>

### Contact Us

- See the tabs *Sales Questions*, *Technical Enquiries*, *Circuit Schematic & PCB Design Review*, *Get Samples* (Online stores), *Become Our Supplier*, *Comments & Suggestions*.  
<http://espressif.com/en/contact-us/sales-questions>

## Revision History

Date	Version	Release Notes
2021-10-26	v1.1	<ul style="list-style-type: none"> <li>• Updated Figure <i>Block Diagram of ESP32-C3</i> to show power modes;</li> <li>• Added CoreMark score in Features;</li> <li>• Updated Table <i>Pin Description</i> to show default pin functions;</li> <li>• Updated Figure <i>ESP32-C3 Power Scheme</i> and related descriptions;</li> <li>• Added Table <i>Mapping of SPI Signals and Chip Pads</i>;</li> <li>• Added note 3 to Table <i>Recommended Operating Conditions</i>;</li> <li>• Other updates to wording.</li> </ul>
2021-05-28	v1.0	<ul style="list-style-type: none"> <li>• Updated power modes;</li> <li>• Updated Section <i>2.4 Strapping Pins</i>;</li> <li>• Updated some clock names and their frequencies in Section <i>3.2 System Clocks</i>;</li> <li>• Added clarification about ADC1 and ADC2 in Section <i>3.3.1 Analog-to-Digital Converter (ADC)</i>;</li> <li>• Updated the default configuration of U0RXD and U0TXD after reset in Table <i>IO MUX Pin Functions</i>;</li> <li>• Updated sampling rate in Table <i>ADC Characteristics</i>;</li> <li>• Updated Table <i>Reliability Qualifications</i>;</li> <li>• Added the link to recommended PCB land pattern in Chapter <i>5 Package Information</i>.</li> </ul>
2021-04-23	v0.8	Updated <i>Wi-Fi Radio</i> and <i>Bluetooth LE Radio</i> data.
2021-04-07	v0.7	<ul style="list-style-type: none"> <li>• Updated information about <i>USB Serial/JTAG Controller</i>;</li> <li>• Added GPIO2 to Section <i>2.4 Strapping Pins</i>;</li> <li>• Updated Figure <i>Address Mapping Structure</i>;</li> <li>• Added Table <i>IO MUX Pin Functions</i> and Table <i>Power-Up Glitches on Pins</i> in Section <i>3.4.1 General Purpose Input / Output Interface (GPIO)</i>;</li> <li>• Updated information about SPI2 in Section <i>3.4.2 Serial Peripheral Interface (SPI)</i>;</li> <li>• Updated fixed-priority channel scheme in Section <i>3.4.8 General DMA Controller</i>;</li> <li>• Updated Table <i>Reliability Qualifications</i>.</li> </ul>
2021-01-18	v0.6	<ul style="list-style-type: none"> <li>• Clarified that of the 400 KB SRAM, 16 KB is configured as cache;</li> <li>• Updated maximum value to standard limit value in Table <i>TX EVM Test</i> in Section <i>4.8.1 Wi-Fi RF Transmitter (TX) Specifications</i>.</li> </ul>

Date	Version	Release Notes
2021-01-13	v0.5	<ul style="list-style-type: none"><li>• Updated information about Wi-Fi;</li><li>• Added connection between embedded flash ports and chip pins to table notes in Section <a href="#">2.2 Pin Description</a>;</li><li>• Updated Figure <a href="#">ESP32-C3 Power Scheme</a>, added Figure <a href="#">ESP32-C3 Power-up and Reset Timing</a> and Table <a href="#">Description of ESP32-C3 Power-up and Reset Timing Parameters</a> in Section <a href="#">2.3 Power Scheme</a>;</li><li>• Added Figure <a href="#">Setup and Hold Times for the Strapping Pins</a> and Table <a href="#">Parameter Descriptions of Setup and Hold Times for the Strapping Pins</a> in Section <a href="#">2.4 Strapping Pins</a>;</li><li>• Updated Table <a href="#">Peripheral Pin Configurations</a> in Section <a href="#">3.11 Peripheral Pin Configurations</a>;</li><li>• Added Chapter <a href="#">4 Electrical Characteristics</a>;</li><li>• Added Chapter <a href="#">5 Package Information</a>.</li></ul>
2020-11-27	v0.4	Preliminary version.



[www.espressif.com](http://www.espressif.com)

## Disclaimer and Copyright Notice

Information in this document, including URL references, is subject to change without notice.

ALL THIRD PARTY'S INFORMATION IN THIS DOCUMENT IS PROVIDED AS IS WITH NO WARRANTIES TO ITS AUTHENTICITY AND ACCURACY.

NO WARRANTY IS PROVIDED TO THIS DOCUMENT FOR ITS MERCHANTABILITY, NON-INFRINGEMENT, FITNESS FOR ANY PARTICULAR PURPOSE, NOR DOES ANY WARRANTY OTHERWISE ARISING OUT OF ANY PROPOSAL, SPECIFICATION OR SAMPLE.

All liability, including liability for infringement of any proprietary rights, relating to use of information in this document is disclaimed. No licenses express or implied, by estoppel or otherwise, to any intellectual property rights are granted herein.

The Wi-Fi Alliance Member logo is a trademark of the Wi-Fi Alliance. The Bluetooth logo is a registered trademark of Bluetooth SIG.

All trade names, trademarks and registered trademarks mentioned in this document are property of their respective owners, and are hereby acknowledged.

**Copyright © 2021 Espressif Systems (Shanghai) Co., Ltd. All rights reserved.**